

SIMULATION-BASED ANALYTICAL DESIGN FOR ALUMINIUM RECYCLING PROCESSING PLANT

*Oluwole Timothy Ojo, Temitope Olumide Olugbade, Babatunde Olamide Omiyale**

Department of Industrial and Production Engineering, Federal University of Technology, P.M.B. 704, Akure, Ondo State, Nigeria.

e-mail: boomiyale@futa.edu.ng

Received: March 30, 2021 • Accepted: June 2, 2021

ABSTRACT

Indiscriminate disposal of beverage cans as waste poses a great threat to the environment, causing flooding, landfill, and blockage of drainages, leading to land pollution and sometimes accident. Hence, there is a need to design a system capable of converting these wastes into usable products. In this study, a simulation-based analytical design for aluminium recycling processing plant was carried out to ascertain the efficiency and reliability of the design before fabrication using finite element analysis (FEA) approach. The simulation results revealed a lesser maximum stress of 6.323 MPa for the furnace outer casing under the action of load with a displacement of 0.0795 mm. The stress of the machine components is less than the yield strength of the selected materials, making the machine fit and workable. The analytical results agree with the numerical analysis; hence the conceptual design is fit for fabrication based on the design analysis and evaluation. After the design analysis and simulation, the designed recycling process plant parts are found to be under negligible deflection and stress which is far below the yield strength of chosen materials.

Keywords. Recycling; aluminium can, ingots, conceptualization; design; simulation based.

1. INTRODUCTION

Aluminium recycling has received a tremendous attention over the years due to the remarkable benefits it offers such as drastic reduction of aluminium volume in landfills, reduction of production costs, and production of added revenue for recyclers [1-3]. However, the environment is being threatened and polluted many times due to the indiscriminate disposal of aluminium beverage cans as wastes. Hence, a recycling process is needed to convert the aluminium wastes to resources, thereby reducing the disposal of cans to the minimum hence providing permanent solution to the common problems caused by the inappropriate disposal of wastes including erosion, flooding, and drainage blockage.

Process plant has been well recognized by many engineers and producers, as an important system for combining several activities together during the manufacturing process. It is a single-unit industrial plant combining several units of machines which is often used to convert raw materials into final product of enhanced quality and properties. The process plant can reduce production time thereby reducing cost, improve the system efficiency, reduce the risks of accident to the minimum on the part of the workers, and reduce the working area or space.

Over the years, modeling and simulation approach has been used to analyze in detail the operating system and performance evaluations of many systems such as heat transfer analysis in a circular jet [4], tricycle rear shock absorber [5], network address translation (NAT)-based enterprise WLAN framework [6], denial of service (DoS) attack and defense [7], predictive analytical architecture for healthcare application [8], water distribution network [9], gate all around (GAA) FET model [10], cooperative transport [11], and shear critical glass fiber-reinforced polymer [12]. In addition, several works have been carried out on the design and analysis of different processing plants in the past. Ab Rahim et al. [13] presented an overview on recycling process of aluminium chips via hot extrusion process at the common temperature of 450°C. The ductility and strength of the Al alloy reportedly reduced as a result of deformation at high temperature. The preheat time and temperature, optimum ram speed and material

strength were the main factors influencing the extrusion process. An extrusion process was also adopted by Patidar et al. [14] using Taughi design approach for recycling of aluminium. Recycling aluminium scraps, alloys and cans via extrusion process and other methods including hot press forging process and powder metallurgy-based method [15] often enables a simplified waste management system [16-17]. The importance of recycling process and recycled materials for several indoor and industrial applications was also emphasized by Grigore [18]. According to Kowang et al. [19], the reliability requirements, performance, cost, and safety remain the most important design criteria for recycling aluminium cans compressor. A recycling process was also carried out by Tekkaya et al. [20] on AA-6060 aluminium chips using hot profile extrusion method.

However, the conceptualization and simulation of an aluminium recycling processing plant for the production of high-grade aluminium ingots has not been properly investigated, hence the need for this study. In the present study, an aluminium recycling processing plant was conceptualized and designed to alleviate the indiscriminate disposal of beverage cans and give an eye opening on the conversion of the assumed waste to aluminium ingots. The performance of the designed process plant was then compared by analytical method and numerical approach through finite element analysis (FEA).

2. DESIGN CONSIDERATIONS AND ANALYSIS

To enhance the efficiency and reliability of the process plant without sacrificing the quality and output, some design factors were considered for the material selection and fabrication process including thermal stability, productivity time, source of power, aluminium output, safety, ease of operation, and cost [21-23].

The aluminium recycling process plant operation principle is achieved in stages and different machines are positioned to actualize this in order of operation with respect to machine in the following order; (1) can compressing machine (can crusher), (2) can shredder, and (3) electrical furnace. The electric resistance furnace is designed with the principle of a heater resistance to electric current flow leading to the production of heat. The material selected for the heater is Cr-Ni 80:20 having 20 % Chromium and 80 % Nickel. The material selection criteria for the different parts of the processing machine are summarized in Table 1.

Table 1. Material selection criteria for aluminium recycling processing plant

Machine Component	Material Selected	Selection Criteria
Can compressing machine		
Hopper volume	Mild steel	Adequate strength, cheap and readily available
Sliding piston	Mild steel	Adequate strength, cheap and readily available
Ram	304 stainless steel (SS)	Adequate strength, corrosion resistance and readily available
Fluid reservoir	304 SS	Adequate strength, corrosion resistance and readily available
Fixed end	Mild steel	Adequate strength, cheap and readily available
Machine frame	Mild steel	Adequate strength, cheap and readily available
Discharge plate	Mild steel	Adequate strength and readily available
Can shredder		
Shredder casing	Mild steel	Adequate strength, cheap and readily available
Gear	High carbon steel	High Strength, hardness, wear resistance and moderate ductility
Machine frame	Mild Steel	Adequate strength and readily available
Crusher blade	High carbon steel	High Strength, hardness, wear resistance and moderate ductility

Gear case	S45C carbon steel	Adequate strength, corrosion resistance and readily available
Outlet channel	Mild steel	Adequate strength and readily available
Hopper	Mild steel	Adequate strength and readily available
Rotating shaft	Mild steel	Adequate strength and readily available
Electric furnace		
Furnace outer casing	316 SS	Adequate strength, refractory, corrosion resistance and readily available
Furnace cover	316 SS	Adequate strength, refractory, corrosion resistance and readily available
Frame	Mild steel	Adequate strength, cheap and readily available
Crucible	304 SS	Adequate strength, high melting point, good conductor, corrosion resistance and readily available
Refractory	Insulating fire brick according to ASTM C155 group 23	Shrinkage less than 2% after 24hr firing at 1230°C, good refractory, readily available and cheap
Heater	Nichrome 80:20	High melting point, safely heat up to 1200°C

3. DESIGN ANALYSIS OF THE PROCESSING PLANT

The crushing of the aluminium cans fed to the compression hopper is pressed against a fixed wall using hydraulic principle powered by a pump, as shown in the exploded view (Figure 1) while the isometric view of process plant is shown in Figure 2. As revealed in Figure 2, the aluminium recycling processing plant comprises of the mold, furnace, conveyor, shredding and compression machine. A self-explanatory drawings and analysis are essential to uncover the operating mechanism as well as the importance of the different parts. Similar to the design analysis in literature [24-28], ease of operation and maintenance was properly considered during the design of the aluminium process plant. The can shredder consists the shredder casing, shredder hopper, crusher blade, ball bearing, outlet channel, frame, gear, electric motor and gear case.

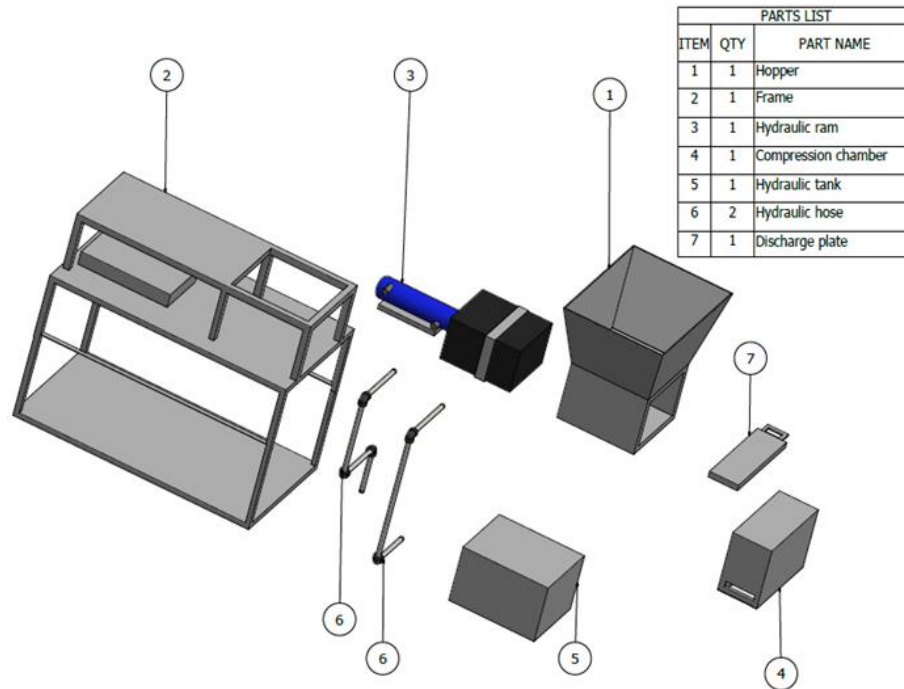

Figure 1. Exploded view of the can compression machine

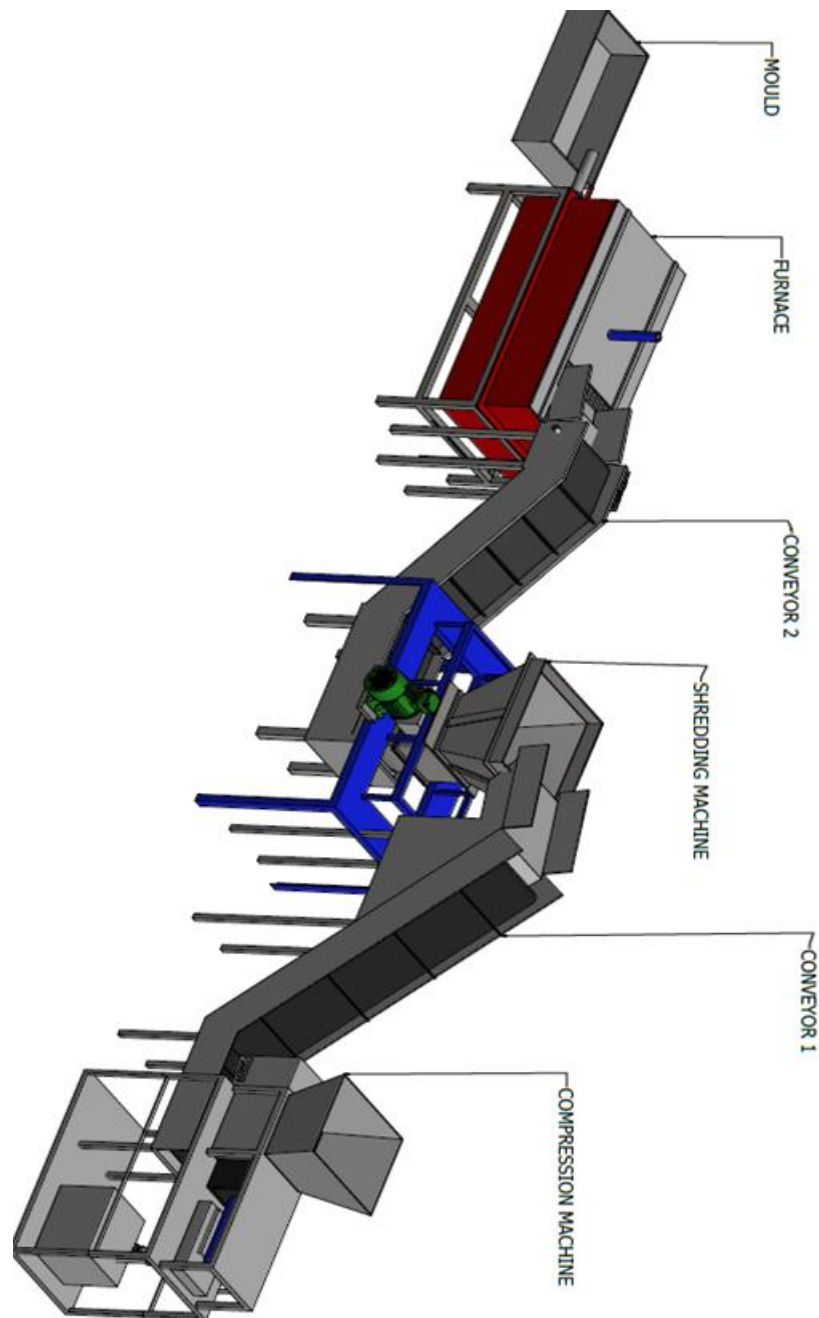

Figure 2. Isometric view of the aluminium recycling processing plant

4. RESULT AND DISCUSSION

4.1 Analytical design of the process plant

The conceptual design of the machines has been done, and the materials selection for its production has been stated. The engineering drawings required for the production of the machine has been made available based on the design values obtained. The expected machine operation principle has been clearly stated. Table 2 - Table 6 summarize the results for the design analysis of the aluminium processing plant including the can compressing machine, cam shredder, electrical furnace, conveyor to the can shredder, and conveyor to the electrical furnace.

Table 2. Summary of design analysis for the can compressing machine part of the processing plant.

Machine Section/Part	Design Model	Design Value
Hopper volume	$V_1 = \frac{1}{3}(B_1H_1 - b_1h_1)$	$V_1 = 0.06983\text{m}^3$
Sliding piston	Volume, $V_0 = ((LBH) - (\pi d_1^2 L_1/4))$ Mass, $M_0 = \rho_p V_0$ Minimum force to move Piston, $F_m = M_0 a$ A Stroke time = t From $(S = ut + \frac{1}{2}at^2)$	$V_0 = 4.516 \times 10^{-3}\text{m}^3$ $M_0 = 35.4506\text{kg}$ $F_m = 106.3518\text{N}$ $t = 0.408\text{s}$
Ram	Volume, $V_r = ((\pi d_1^2 L_2/4) + (\pi d_1^3/16)) - ((\pi d_2^2 L_2/4) + (\pi d_2^3/16))$	$V_r = 6.016 \times 10^{-4}\text{m}^3$
Fluid reservoir	$V_{r1} = L^3$	$V_{r1} = 0.008\text{m}^3$
Minimum force needed to move piston head	Force, $F_m = M_0 a$	$F_m = 106.3518\text{N}$
Hydraulic pipe	Cross sectional area, $A_p = \pi d^2/4$ Volume flow rate, $Q = \text{Volume} / \text{time}$ Velocity of flow, $V_p = Q/A_p$ Power through pipe, $P_n = \frac{1}{2} (\rho A_p v^3)$ Workdone on fluid, $W_f = P_n \times \text{time}$	$A_p = 7.854 \times 10^{-5}\text{m}^2$ $Q = 0.001413\text{m}^3/\text{s}$ $= 5.0868\text{m}^3/\text{hr}$ $V_p = 17.99\text{m/s}$ $P_n = 193.956\text{W}$ $W_f = 79.134\text{J}$
Reciprocating pump	Power, $P_p = Q\rho gH/(3.6 \times 10^6)\eta$	$P_p = 0.013425 \text{ kW} = 13.425\text{W}$
Fixed end plate	Stress, $\sigma_p = F/A$	$\sigma_p = 15230.725\text{Nm}^{-2}$
Pump	Power, $P_p = \frac{Q \cdot P}{\eta}$	320.07 W 1hp hydraulic actuator pump is selected

Table 3. Summary of design analysis for the can shredder part of the processing plant.

Machine Section/Part	Design Model	Design Value
Hopper volume	$V_2 = \frac{1}{3}(B_2H_2 - b_2h_2)$	$V_2 = 0.173733\text{m}^3$
Shaft 1 and 2	Volume (V_0) = $((\pi d^2)/4) * L$	$V_0 = 7.5398 \times 10^{-4} \text{m}^3$
Shaft 1 and 2	Mass (M_0) = $M_0 \times \rho$	$M_0 = 5.9187\text{kg}$
Shaft 1 and 2 velocity	$V = \frac{2\pi N}{60} \cdot \frac{d}{2}$	$V = 0.2094 \text{m/s}$
Turning force if shaft 1 and 2	$F_t = \frac{2M_0V^2}{d}$	$F_t = 12.98 \text{N}$
Torque of shaft (T)	$T = \frac{\tau}{J} \cdot \frac{d}{2}$	$T = 565486.7 \text{Nmm}$ $= 565.4867 \text{Nm}$
Shaft angle of twist (Θ)	$\frac{\tau}{d/2} = \frac{T}{J} = \frac{C \cdot \theta}{L}$	$0.01687 \text{rad} = 0.96658^\circ$
Power needed to rotate shaft (P)	$P = T\omega = \frac{2\pi NT}{60}$	$P = 5921.763 \text{W} = 5.922 \text{kW}$
Maximum shear strain in the shaft (e_s) _{max}	$(e_s)_{max} = \frac{d \cdot \theta}{2L}$	5.62×10^{-4}
Torsional rigidity (k)	$k = \frac{T}{\theta}$	33520.0255Nm/rad
Bending moment of shaft 1	$B.M = (WL/2)/2 = WL/4$	$B.M = 8700.495\text{Nmm}$
Shaft 1 angle of deflection	$\theta_{max} = \frac{-WL^2}{EI \cdot 16}$	$\Theta_{max} = -0.002975^\circ$
Shaft 1 deflection	$y = \frac{-WL^3}{48EI}$	$y = -1.0386 \times 10^{-5} \text{m}$ $= -1.0386 \times 10^{-5} \text{m} \approx$
Shaft 2 angle of deflection	$\theta_B = \frac{-WL^2}{2EI}$	$\theta_B = -4.1543 \times 10^{-4} \text{rad} =$ -0.0238°
Possible maximum deflection (y_{max}) that could occur in shaft 2	$y_{max} = \frac{-W}{EI} \left(L \cdot \frac{L^2}{2} - \frac{L^3}{6} \right) = \frac{-WL^3}{3EI}$	$y_{max} = 0.00016617 \text{m} \approx$ 0.166mm
Gear circular pitch	$P_c = \text{Circular pitch} = \pi m$	$P_c = 3\pi = 9.4247 \approx$ 9.425mm
Center distance between pitch circle	$X = \text{Center distance between pitch circle} = \frac{D_1 + D_2}{2}$	$X = 60\text{mm}$
Pitch line velocity	$v = \text{Pitch line velocity} = \frac{\pi DN}{60}$	$V = 0.6283\text{m/s}$
Velocity factor	$C_v = \frac{3}{3 + v}$	$C_v = 0.8268$
Permissible working stress	$\sigma_w = \sigma_o \times C_v$	$\sigma_w = 57.876\text{Nmm}^{-2}$
Tangential load on a tooth	$W_T = \sigma_w \cdot b \cdot \pi m \cdot y$	$W_T = 1959.32 \text{N}$

Table 4. Summary of design analysis for the electrical furnace part of the processing plant.

Machine Section/Part	Design Model	Design Value
Volume of crucible	$V_3 = LBH$	$V_3 = 945000000\text{mm}^3 =$ 0.945m^3

Limited volume of crucible to be used	$V_4 = 80\% \text{ of } V_3$	$= 0.756\text{m}^3$
Mass of molten aluminium of 756km ³ volume (m ₁)	$m_1 = \text{Density of molten aluminium} \times 0.756\text{m}^3$	$m_1 = 1795.5\text{kg}$
Quantity of heat needed to melt aluminium and raise it to 700°C (Q _T)	$Q_T = m_1 C_{Al} ((T_2 - T_1) + (T_3 - T_2)) + m_1 L_{Al}$	$1811659500\text{J} = 1.812 \text{ X GJ}$
Total thermal conduction resistance	$R_{th.con} = \frac{(0.03k_f + L_f k_s)}{k_s k_f} \times \left(\frac{1}{A_1} + \frac{1}{A_2} + \frac{1}{A_3} + \frac{1}{A_4} + \frac{1}{A_5} + \frac{1}{A_6} \right)$	$R_{th.con} = 0.58917 \text{ m}^2/\text{s}^0\text{K/kJ}$
Heat loss to crucible (absorbed)	Heat use for raising material to 800 °C $= m_s C_{st} (800 - 20)$	$1400 \times 502.416 \times 780 = 548638272 \text{ J}$
Total heat to be produced (Q _t)	$= \text{Heat for melting Aluminium} + \text{Heat loss by conduction} + \text{Heat loss to crucible}$	$2361451938 \text{ J} \approx 2.361 \text{ GJ}$
Furnace Efficiency (η _f)	$\eta_f = \frac{\text{useful heat}}{\text{total heat}}$	76.72%
Time needed to melt filled aluminium (T)	$T = \frac{Q_t}{I.V. (60 \times 60)}$	7.809 hours ≈ 8 hours

Table 5. Summary of design analysis for the conveyor delivering to can shredder part of the processing plant.

Machine Section/Part	Design Model	Design Value
Length (L5)	$L5 = \sqrt{h^2 + l^2}$	$L5 = 1.281 \text{ m}$
Mass of belt	$\rho_b \cdot L \cdot b \cdot w$	141.3L kg
Belt weight	$W_b = \frac{m_b}{L} \cdot 9.81$	$1386.153 \frac{\text{kg}}{\text{m}}$
Number of carrying idlers for L6	$t_c = \frac{L6}{Z_{c6} + 1}$	$Z_{c6} = 19.3443 \approx 19 \text{ idlers}$
Number of carrying idlers for L3	$t_c = \frac{L3}{Z_{3c} + 1}$	$Z_{3c} = 7.33 \approx 7 \text{ idlers}$
Number of return idlers for L1	$t_r = \frac{L1}{Z_{r1} + 1}$	$Z_{c5} = 7.33 \approx 7 \text{ idlers}$
Number of return idlers for L2	$t_r = \frac{L2}{Z_{r2} + 1}$	$Z_{c5} = 10.667 \approx 11 \text{ idlers}$
Possible number of compressed cans	$n_c = \frac{1.72}{0.2094 \times 0.408}$	$= 20.13 \approx 20$

Mass per unit meter of aluminium conveyed	$m_m = \frac{216.66}{1.72}$	$= 125.97 \text{ kg/m}$
Load resistance due to lifting of material (F_f)	$F_f = W_m \cos \theta = m_m \cdot L \cdot g \cdot \cos \theta$	$F_f = 1076.073 \text{ N}$
Component of load along belt	$F_m = W_m \sin \theta = m_m \cdot L \cdot g \cdot \sin \theta$ $= m_m \cdot g \cdot h$	$F_m = 865.0356 \text{ N}$
Frictional resistance due to carrying idlers F_{cr}	$F_{cr} = F_c \left(m_m + m_b + \frac{m_i z_c}{l} \right) gl$	$F_{cr} = 113.9044 \text{ N}$
Frictional resistance due to return idlers F_r	$F_r = F_c \left(m_b + \frac{m_i z_r}{l} \right) gl$	$F_{cr} = 75.5012 \text{ N}$
Minimum diameter of conveyor driver drum	$d_A = \frac{f_u \cdot C_3 \cdot 180}{b_0 \cdot \beta}$	$d_A = 60.38 \text{ mm} \approx 60 \text{ mm}$ $= 0.06 \text{ m}$

Table 6. Summary of design analysis for the conveyor delivering to electrical furnace part of the processing plant.

Machine Section/Part	Design Model	Design Value
Belt weight	$W_b = \frac{m_b}{L} \cdot 9.81$	$1386.153 \frac{\text{kg}}{\text{m}}$
Number of carrying idlers for L6	$t_c = \frac{L6}{Z_{c6} + 1}$	$Z_{c6} = 4.833 \approx 5$ idlers
Number of carrying idlers for L5	$t_c = \frac{L5}{Z_{5c} + 1}$	$Z_{c5} = 20.35 \approx 20$ idlers
Number of return idlers for L4	$t_c = \frac{L4}{Z_{c4} + 1}$	$Z_{c5} = 10.66 \approx 11$ idlers
Number of return idlers for L1	$t_r = \frac{L1}{Z_{r1} + 1}$	$Z_{r1} = 3.16 \approx 3$ idlers
Number of return idlers for L2	$t_r = \frac{L2}{Z_{r2} + 1}$	$Z_{r2} = 8.667 \approx 9$ idlers
Possible number of crushed to block cans (N_o)	$N_o = \frac{\text{Volume of compressed cans}}{\text{volume of shredder hopper}}$	$50.6 \approx 51$
Load resistance due to lifting of material (F_f)	$F_f = W_m \cos \theta$	$F_f = 2855.312 \text{ N}$
Component of load along belt	$F_m = W_m \sin \theta = m_m \cdot L \cdot g \cdot \sin \theta$ $= m_m \cdot g \cdot h$	$F_m = 3596.43 \text{ N}$
Frictional resistance due to carrying idlers F_{cr}	$F_{cr} = F_c \left(m_m + m_b + \frac{m_i z_c}{l} \right) gl$	298.0877 N
Frictional resistance due to return idlers F_r	$F_r = F_c \left(m_b + \frac{m_i z_r}{l} \right) gl$	127.1003 N

Minimum diameter of conveyor driver drum	$d_A = \frac{f_u \cdot C_3 \cdot 180}{b_0 \cdot \beta}$	$d_A = 192.63 \text{ mm} \approx 200 \text{ mm} = 0.2 \text{ m}$
Velocity of drum drive and belt speed (V)	$V = \frac{\pi d_A N}{60}$	$V = 0.2094 \text{ m/s}$
Electric motor power (P _m)	$P_m = \frac{P_A}{\eta}$	$P_m = 1498.185 \text{ W} \approx 1.498 \text{ kW} \approx 1.5 \text{ hp}$

4.2 Simulation-based design

The simulation was done using Autodesk inventor software and the results are analyzed. Figure 3 shows the simulation of the furnace frame; with the simulation displacement result of furnace frame when loaded shown in Figure 3(a), furnace frame simulation Von Mises stress result in Figure 3(b), and furnace frame stress XY simulation result in Figure 3(c). From the result simulation result of the electrical furnace frame, a maximum stress of 55.91 MPa which is lesser than the yield strength (207 MPa) of the material, can be experienced by the frame. In addition, the displacement experienced by the electrical furnace frame due to the applied force and pressure, can be up to 1.023 mm. The displacement is very negligible, having no effect on the component, hence no failure of part under operation. Figures 3(d-f) show the simulation of can compressing machine frame. As revealed in Figure 3(d), the maximum stress experienced by the frame is 3.12853 MPa. The displacement experienced by the can compressing machine frame due to the applied force and pressure is 0.02018 mm, as shown in Figure 3(e) and summarized in Figure 3(f).

The result obtained from the simulation of the can compressing machine piston head (Figures 3(g-i)) shows that the maximum stress experienced by the frame which can be as high as 0.27179 MPa (Figure 3(g)). Due to the applied force and pressure, the displacement experienced by the can compressing machine piston head can be up to 0.00025654 mm, as revealed in Figures 3(h-i).

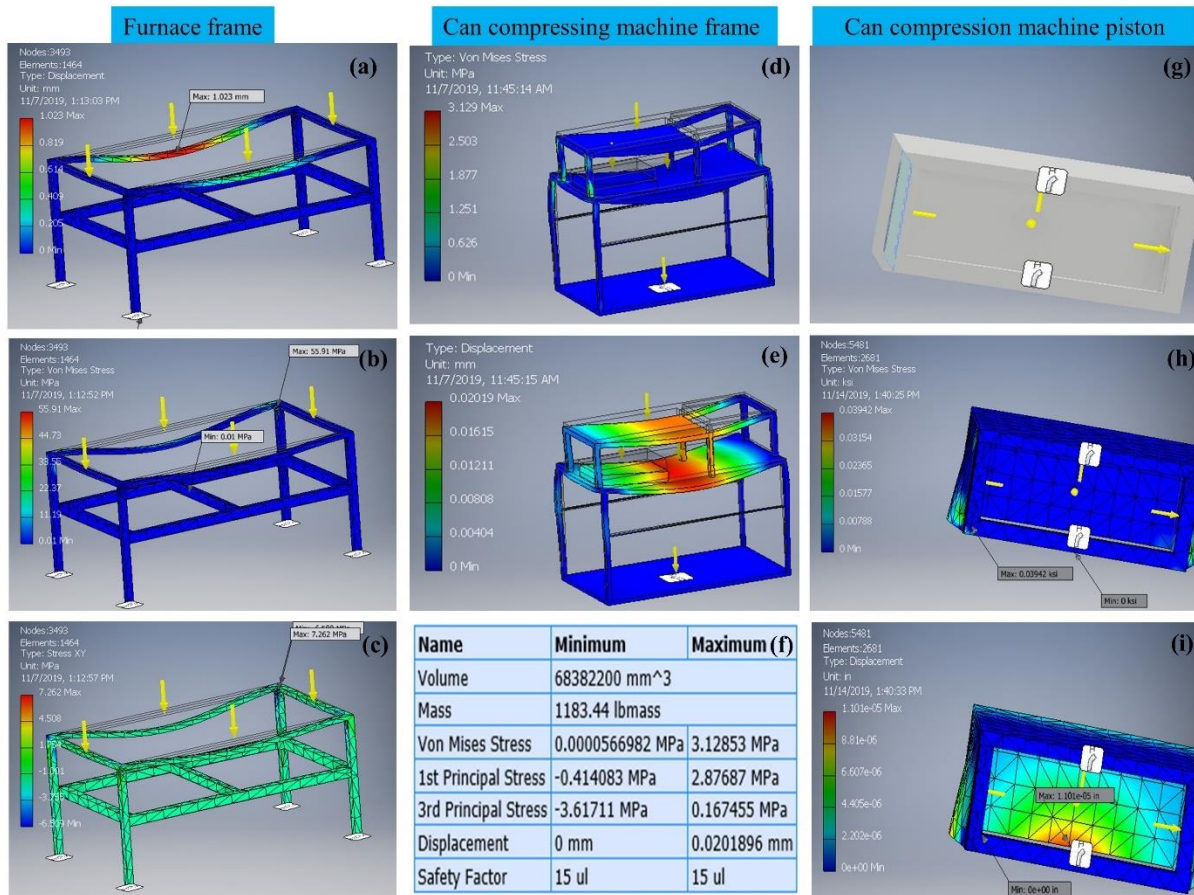

Figure 3. Simulation of the furnace frame, can compressing machine frame, and can compression machine piston head; (a) simulation displacement result of furnace frame when loaded, (b) furnace frame simulation Von Mises stress result, (c) furnace frame stress XY simulation result, (d) can compressing machine frame Von Mises stress simulation result, (e) can compressing machine frame displacement result of simulation, (f) summary of the can compressing machine simulation result, (g) can compression machine piston head at no load, (h) Von Mises stress result of can compression machine piston head, (i) displacement result of piston head.

Figure 4 shows the simulation results for the can shredder gear, can shredder base cover, and electrical furnace refractory cover. Figure 4(a) shows the result obtained from the simulation of the can shredder gear tooth revealing the maximum stress experienced by the frame to be 7.559 MPa. From Figure 4(b), a displacement of 0.00001 mm can be obtained for the can shredder gear tooth due to the applied force and pressure. Figure 4(c) reveals the Von Mises stress simulation result showing a tooth on gear.

Figure 4(d) shows the result obtained from the simulation of the label removal machine frame revealing the maximum stress experienced by the frame to be 4.293 MPa. In addition, a very small displacement of about 0.005357 mm (Figure 4(e)) can be experienced by the label removal machine frame due to the applied force and pressure. The negligible displacement obtained indicates that the component cannot be affected and hence no failure will occur under operation. This is also confirmed by the displacement simulation result on can shredder base, as revealed in Figure 4(f).

Figure 4(g) shows the simulation results of the electrical furnace refractory with the maximum stress of 6.323 MPa for the frame. The subsequent displacement obtained for the electrical furnace refractory is 0.07954 mm (Figure

4(h)), which can be attributed to the effect of the applied force and pressure. The displacement of the electrical furnace refractory cover simulation result showing the base is revealed in Figure 4(i). Table 7 summarizes the simulation results for the processing plants.

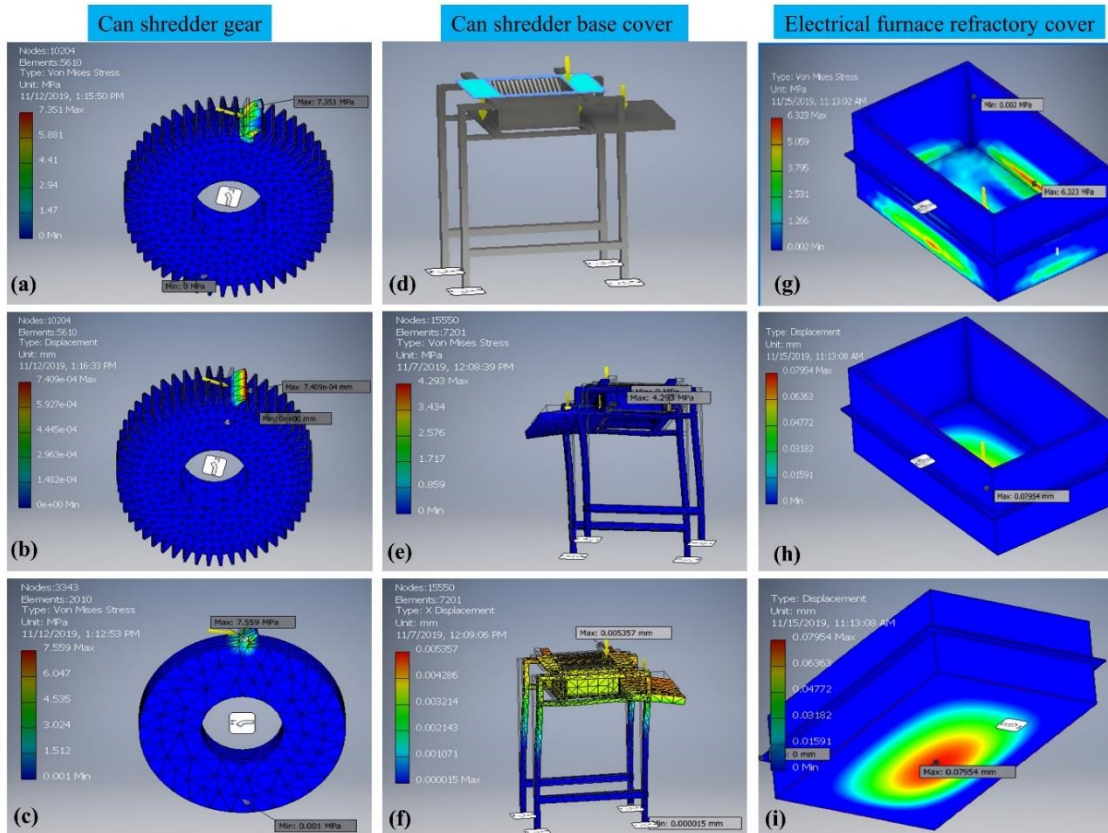

Figure 4. Simulation of can shredder gear; (a) Von Mises stress simulation result on a gear tooth, (b) displacement result on the gear tooth, (c) Von Mises stress simulation result showing a tooth on gear; simulation of can shredder base cover: (d) can shredder base with frame at no load, (e) Von Mises stress simulation result on can shredder base with frame, (f) displacement simulation result on can shredder base; electrical furnace refractory cover: (g) Von Mises electrical refractory cover stress simulation result, (h) displacement of electrical refractory cover simulation result, (i) displacement of electrical furnace refractory cover simulation result showing base.

In this study, the stress of the machine components is less than the yield strength, making the machine fit and workable. In addition, as revealed in Table 7, the analytical and simulation results agree with each other, hence the conceptual design is fit for fabrication based on the design analysis and evaluation, using the available materials.

Table 7. Comparison of results (maximum stress) for both analytical method and numerical simulation

Parts	Analytical method (MPa)	Numerical method (MPa)
Electrical furnace frame	56.902	55.910
Can compressing machine Frame	3.500	3.128

Can compression machine piston head	0.310	0.272
Can shredder gear	7.920	7.559
Can shredder base cover	4.523	4.293
Electrical furnace refractory cover	6.632	6.323

Simulation-based approach is not only core to recycling and resource efficiency, but also validate and evaluate the performance of analytical model which makes it to be an important tool in many applications including anti-synchronization of non-identical hyperchaotic systems [29], double circuit transmission system [30], indoor temperature control [31], traffic flow variables at network [32], etc. In the present study, the simulation-based designed process plant will find applications in many beverage manufacturing industries for the production of high-quality aluminium ingots through recycling, hence reducing the amount of wastes to the minimum [33].

5. CONCLUSIONS

In summary, a simulation-based analytical design for aluminium recycling processing plant was carried out for the production of high-grade aluminium ingots. The plant was designed to have a compression section, a shredding section, a furnace where melting process is achieved, and conveyors positioned between sections. The design analysis of each of the machine element was done and structural integrity of the machine design was evaluated using finite element modeling. The simulation results revealed a lesser maximum stress of 6.323 MPa for the furnace outer casing under the action of load with a displacement of 0.0795 mm, whereas the analytical method yielded a maximum stress of 6.632 MPa. Regarding the electrical furnace frame, the maximum stress of 56.902 MPa and 55.910 MPa were obtained for the analytical and numerical methods, respectively. The stress of the machine components is less than the yield strength, making the machine fit and workable. The analytical and simulation results agree with each other; hence the conceptual design is fit for fabrication based on the design analysis and evaluation, using the available materials. The developed aluminium recycling processing plant will find applications in many beverage manufacturing industries for the production of high-quality ingots.

CONFLICT OF INTEREST

The authors declare no conflict of interest.

ACKNOWLEDGEMENTS

The authors sincerely appreciate the efforts of Ogundipe Babatunde Moses for assistance in the design and simulation aspects of this work.

REFERENCES

- [1] E.E. Ekpe, S.B. Yahaya, F. Achema, O.M. Fabiyi, Design and fabrication of aluminium melting furnace using locally available materials, *Journal of Scientific and Engineering Research*, 2, (2015), 36-43.
- [2] K.A. Isaffar, M.H. Bdeir, Recycling of aluminium beverage cans. *Journal of Engineering and Development* 12, (2008), 157- 163.
- [3] V.S. Meriga, A.D. Boyina, C. Vandana, Design and fabrication of low-cost electrical resistance based metal melting furnace for casting applications, *Leonado Electric Journal of Practices and Technology*, 32, (2018), 41-54.

- [4] B. Abdullah, B. Seyfettin, Flow and heat transfer investigation of a circular jet issuing on different types of surfaces, *Sādhanā*, 44, (2019), 242.
- [5] T.O. Olugbade, T.I. Mohammed, O.T. Ojo, Static stress analysis and displacement of a tricycle rear shock absorber using finite element analysis, *Leonardo Electronic Journal of Practices and Technologies*, 33, (2018), 139-158.
- [6] S. Arkadeep, M.S. Krishna, Testbed evaluation of a seamless handover mechanism for an SDN-based enterprise WLAN, *Sādhanā*, 44, (2019), 243.
- [7] K. Bhupender, B. Bubu, Using game theory to model DoS attack and defence, *Sādhanā*, 44, (2019), 245.
- [8] C. Vikas, G. Raghvendra, T. Aruna, S. Anupam, Real-time big data and predictive analytical architecture for healthcare application, *Sādhanā*, 44, (2019), 237.
- [9] H. Nikhil, M. Ashutos, O.M. Damani, A Series of ILP models for the optimization of water distribution networks, *Sādhanā*, 44, (2019), 239.
- [10] A. Amit, P.C. Pradhan, P.S. Bibhu, Effects of the physical parameter on gate all around FET, *Sādhanā*, 44, (2019), 248.
- [11] B. Teka, A. Dutta, Modeling and simulation of cooperative transport of an object by two mobile manipulators on an uneven terrain using KSOM network, *International Journal of Modelling and Simulation*, (2019), DOI: 10.1080/02286203.2019.1670034.
- [12] A. Md Shah, A. Hussein, Finite element modelling of shear critical glass fibre-reinforced polymer (GFRP) reinforced concrete beams, *International Journal of Modelling and Simulation*, (2019), DOI: 10.1080/02286203.2019.1655702.
- [13] S.N. Ab Rahim, M.A. Lajis, S. Ariffin, A Review on Recycling Aluminum Chips by Hot Extrusion Process, *Procedia CIRP*, 26, (2015), 761 – 766.
- [14] D. Patidar, Er. A. Tiwari, P. Patidar, Recycling of aluminium by extrusion process with annova or taguchi design approach, *Journal of Emerging Technologies and Innovative Research*, 3, (2016), 76-83.
- [15] S. Kumar, F. Mathieux, G. Onwubolu, V. Chandra. A novel powder metallurgy-based method for the recycling of aluminum adapted to a small island developing state in the Pacific, *International Journal of Environmentally Conscious Design & Manufacturing*, ECM Press, 13, (2007), 1-22.
- [16] M. Samuel, A new technique for recycling aluminium scrap, *Journal of Materials Processing Technology*, 135, (2003), 117-124.
- [17] M. Mahfoud, D. Emadi, Aluminum recycling-challenges and opportunities. *Advanced Materials Research*, 83, (2010), 571-578.
- [18] M.E. Grigore, Methods of recycling, properties and applications of recycled thermoplastic polymers, *Recycling*, 2, (2017), 24.
- [19] T.O. Kowang, C.S. Long, A.B.M. Rasli, M.A.B.M. Daril, I. Mustapha, Recycling of aluminium – developing design criteria for aluminium cans compressor, *Advanced Materials Research*, 845, (2014), 489-493.
- [20] A.E. Tekkaya, M. Schikorra, D. Becker, D. Biermann, N. Hammer, K. Pantke. Hot profile extrusion of AA-6060 aluminium chips, *Journal of Materials Processing Technology*, 209, (2009), 3343-3350.
- [21] T.I. Ogedengbe, T.O. Olugbade, O.R. Olagunju, Application of house of quality matrix to material selection for engineering designs, *British Journal of Applied Science and Technology* 10, (2015), 1 – 11.
- [22] B.O. Akinnuli, T.O. Olugbade, Application of queue model for performance assessment of multi-channel multi-servers motor spirit filling station, *International Journal of Engineering and Innovative Technology*, 3, (2014), 74 – 81.
- [23] T.E. Abioye, T.O. Olugbade, T.I. Ogedengbe, Welding of dissimilar metals using gas metal arc and laser welding techniques: A review, *Journal of Emerging Trends in Engineering and Applied Sciences*, 8, (2017), 225-228.
- [24] B.O. Akinnuli, T.O. Olugbade, Development and performance evaluation of piggery and water hyacinth waste digester for biogas production, *International Journal of Engineering and Innovative Technology*, 3, (2014), 271 – 276.
- [25] A.O. Akinola, T.O. Olugbade, T.M. Adamolekun, Development of a 3-seater chair-bed, *International Journal of*

- Engineering and Innovative Technology 4, (2014), 177 – 181.
- [26] T.I. Mohammed, T.O. Olugbade, G.A. Odesanmi, Development and performance evaluation of a pedal operated hydraulic jack, *Journal of Scientific Research and Reports*, 8, (2015), 1 – 8.
- [27] O.T. Ojo, T.O. Olugbade, Development of an adjustable multi nut tighter or remover for car tyre, *Leonardo Electronic Journal of Practices and Technologies*, 32, (2018), 27-40.
- [28] T.O. Olugbade, O.T. Ojo, Development and performance evaluation of an improved electric baking oven, *Leonardo Electronic Journal of Practices and Technologies*, 33, (2018), 189-206.
- [29] A. Ibraheem, A. Khan, Multi-switching compound-compound anti-synchronization of non-identical hyperchaotic systems, *International Journal of Modelling and Simulation*, (2019), DOI: 10.1080/02286203.2019.1697413.
- [30] R. Nale, H. Verma, M. Biswal, An Enhanced Fuzzy Rule Based Protection Scheme for TCSC Compensated Double Circuit Transmission System, *International Journal of Modelling and Simulation*, (2019, DOI: 10.1080/02286203.2019.1692299
- [31] D.K. Jana, S. Basu, Novel Internet of Things (IoT) for controlling indoor temperature via Gaussian type-2 fuzzy logic, *International Journal of Modelling and Simulation*, (2019), DOI: 10.1080/02286203.2019.1682420.
- [32] R. Mohan, Multi-class AR model: comparison with microsimulation model for traffic flow variables at network level of interest and the two-dimensional formulation. *International Journal of Modelling and Simulation*, (2019), DOI: 10.1080/02286203.2019.1675015.
- [33] T.I. Ogedengbe, T.M. Adamolekun, T.O. Olugbade, Strategies for enhancing management of cell-phone waste in Nigeria, *Proceedings of the 2016 Annual Conference of the School of Engineering & Engineering Technology, FUTA*, (2016), 470 – 477.