



## COMPUTER AIDED GEOMETRIC MODELLING OF CYLINDRICAL WORM GEAR DRIVE HAVING ARCHED PROFILE

*S. Bodzás*

Department of Mechanical Engineering, University of Debrecen, H-4028 Debrecen, Óttemető str. 2-4.  
e-mail: bodzassandor@eng.unideb.hu

### ABSTRACT

The objective of this publication is creation of computer geometric models (CAD) of developed in Diósgyőri Machine Factory and using exact production geometry first produced (grinded) cylindrical worm gear drive having arched profile by Illés Dudás [3, 4, 5] for connection analysis, Finite Element Method analysis, etc.

Since the worm and worm gear wrap each other, that is why the worm gear has to be produced by a tool geometry of which is similar to the worm geometry. Knowing of the Connection I. Statement tooth surface of driven element which is wrapped by driver element is defined by numerical calculations.

The CAD model of the worm gear could be designed by adaptation of interpolating B – spline surface to the tooth surface points of worm gear.

Keywords: worm, worm gear, hob, CAD, modelling

### 1. INTRODUCTION

One the most modern types of cylindrical helicoidal surfaces is the worm generated using a circular profile tool.

Contact surfaces between worms having ruled surfaces (Archimedian, convolute, involute types) and mated worm gears do not allow the formation of a continuous, high pressure bearing oil film. It is best to build up an oil film between mated surfaces so that the direction of the relative velocity of the drive faces into the direction normal to the common contact curve or very close to it [2, 3, 4].

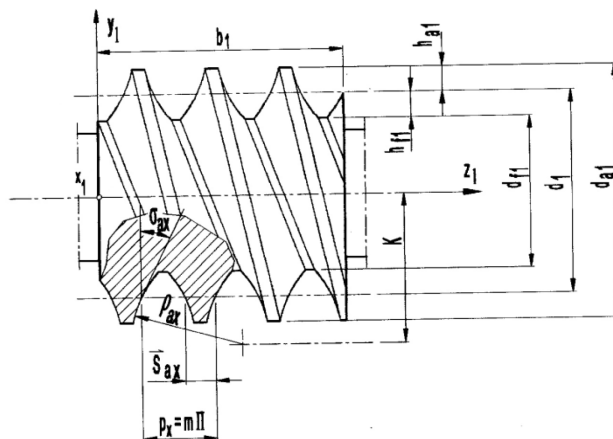

Figure 1. Cylindrical worm having arched profile [3]

A further advantage of mated elements having curved profile is that radius of mating flank surfaces are situated on the same side of the contact point common tangent, that is concave and convex surfaces are in contact, generating relatively small Hertz stress [2, 8].

As a consequence of smaller contact pressure, the load-carrying oil film can form easier.

As a result of arched profile teething the tooth shape and the suitable positioning of the centre of curvature of tooth flank (the position of engagement line) the dedendum tooth thicknesses, both on the worm  $\bar{S}_{1F}$  and worm gear  $\bar{S}_{2F}$ , are significantly wider [2, 6].

## 2. DEFINING OF COORDINATE SYSTEMS

The Illés Dudás type general mathematical model which is appropriate for mathematical modelling of production technologies methods is considered for defining of the necessary coordinate systems for modelling [3, 5].

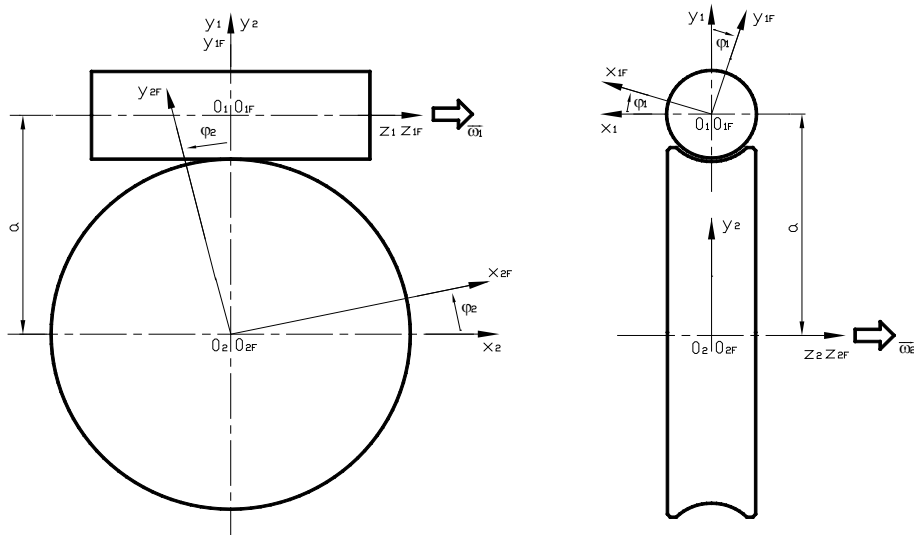

Figure 2. Coordinate systems dispositions for modelling of cylindrical worm gear drive

For the description of the motion relations we define the own motion of each coordinate system. Thus  $K_{1F}$  ( $x_{1F}$ ,  $y_{1F}$ ,  $z_{1F}$ ) coordinate system rotates with

$$\bar{\omega}_1 = \frac{d\varphi_1}{dt} = const. \quad (1)$$

angular velocity in  $K_{1cs}$  ( $x_{1cs}$ ,  $y_{1cs}$ ,  $z_{1cs}$ ) stationary coordinate system [3, 5, 7].

The  $K_{2F}$  ( $x_{2F}$ ,  $y_{2F}$ ,  $z_{2F}$ ) coordinate system in the  $K_2$  ( $x_2$ ,  $y_2$ ,  $z_2$ ) coordinate system rotates with

$$\bar{\omega}_2 = \frac{d\varphi_2}{dt} = const. \quad (2)$$

angular velocity [3, 5, 7].



Transformation matrices between the  $K_{1F}(x_{1F}, y_{1F}, z_{1F})$  rotational coordinate system fixed to member 1 and the  $K_{2F}(x_{2F}, y_{2F}, z_{2F})$  rotational coordinate system fixed to member 2 are (Fig. 2):

$$M_{2F,1F} = M_{2F,2} \cdot M_{2,1} \cdot M_{1,1F} = \begin{bmatrix} \sin \varphi_2 \cdot \sin \varphi_1 & \sin \varphi_2 \cdot \cos \varphi_1 & \cos \varphi_2 & a \cdot \sin \varphi_2 \\ \sin \varphi_1 \cdot \cos \varphi_2 & \cos \varphi_2 \cdot \cos \varphi_1 & -\sin \varphi_2 & a \cdot \cos \varphi_2 \\ -\cos \varphi_1 & \sin \varphi_1 & 0 & 0 \\ 0 & 0 & 0 & 1 \end{bmatrix} \quad (3)$$

$$M_{1F,2F} = M_{1F,1} \cdot M_{1,2} \cdot M_{2,2F} = \begin{bmatrix} \sin \varphi_2 \cdot \sin \varphi_1 & \sin \varphi_1 \cdot \cos \varphi_2 & -\cos \varphi_1 & -a \cdot \sin \varphi_1 \\ \cos \varphi_1 \cdot \sin \varphi_2 & \cos \varphi_1 \cdot \cos \varphi_2 & \sin \varphi_1 & -a \cdot \cos \varphi_1 \\ \cos \varphi_2 & -\sin \varphi_2 & 0 & 0 \\ 0 & 0 & 0 & 1 \end{bmatrix} \quad (4)$$

### 3. GENERATION OF THE TOOTH SURFACE POINTS OF WORM GEAR

The dentation of worm gear is produced by hob which has similar geometry to worm connecting with worm gear based on the direct motion mapping [1, 2, 3, 4].

That is why we have to know the two parametric equations of the cutting edge of hob for modelling [3, 4]:

$$\begin{aligned} x_{1F} &= -\eta \cdot \sin \vartheta \\ y_{1F} &= \eta \cdot \cos \vartheta \\ z_{1F} &= p \cdot \vartheta - \sqrt{\rho_{ax}^2 - (K - \eta)^2} \end{aligned} \quad (5)$$

The tooth surface points of worm gear are determined by direct kinematic method. Knowing the cutting edge of hob and the Connection I. Statement we search the tooth surface points of worm gear which are generated by mutual wrapping.

The relative velocity vector is in the  $K_{1F}$  system:

$$\vec{v}_{1F}^{(12)} = M_{1F,2F} \cdot \frac{dM_{2F,1F}}{dt} \cdot \vec{r}_{1F} = P_{1k} \cdot \vec{r}_{1F} \quad (6)$$

Based on (6) the derived matrix is:

$$\frac{d}{dt} M_{2F,1F} = \begin{bmatrix} i_{21} \cdot \cos \varphi_2 \cdot \sin \varphi_1 & i_{21} \cdot \cos \varphi_2 \cdot \cos \varphi_1 & -i_{21} \cdot \sin \varphi_2 & a \cdot i_{21} \cdot \cos \varphi_2 \\ + \sin \varphi_2 \cdot \cos \varphi_1 & -\sin \varphi_2 \cdot \sin \varphi_1 & & \\ \cos \varphi_1 \cdot \cos \varphi_2 & -i_{21} \cdot \sin \varphi_2 \cdot \cos \varphi_1 & -i_{21} \cdot \cos \varphi_2 & -a \cdot i_{21} \cdot \sin \varphi_2 \\ -i_{21} \cdot \sin \varphi_2 \cdot \sin \varphi_1 & -\cos \varphi_2 \cdot \sin \varphi_1 & & \\ \sin \varphi_1 & \cos \varphi_1 & 0 & 0 \\ 0 & 0 & 0 & 0 \end{bmatrix} \quad (7)$$



The  $P_{1k}$  matrix of the kinematic motion mapping is:

$$P_{1k} = \begin{bmatrix} 0 & -1 & -i_{21} \cdot \sin \varphi_1 & 0 \\ 1 & 0 & -i_{21} \cdot \cos \varphi_1 & 0 \\ i_{21} \cdot \sin \varphi_1 & i_{21} \cdot \cos \varphi_1 & 0 & a \cdot i_{21} \\ 0 & 0 & 0 & 0 \end{bmatrix} \quad (8)$$

If  $\eta$  and  $\vartheta$  parameters are independent from one another, then the normal vector can be calculated by the following way [2, 5]:

$$\vec{n}_{1F} = \frac{\partial \vec{r}_{1F}}{\partial \eta} \times \frac{\partial \vec{r}_{1F}}{\partial \vartheta} \quad (9)$$

The equations of the tooth surface of member 2 which can be defined as the mashing surface of the group of contact lines in the  $K_{2F}$  coordinate system [3, 7]:

$$\begin{aligned} \vec{n}_{1F} \cdot \vec{v}_{1F}^{(12)} &= 0 \\ \vec{r}_{1F} &= \vec{r}_{1F}(\eta, \vartheta) \\ \vec{r}_{2F} &= M_{2F,1F} \cdot \vec{r}_{1F} \end{aligned} \quad (10)$$

Knowing of the (10) equations we have worked out a computer program in case of a concrete cylindrical worm gear drive [2, 3, 5] for producing of the tooth surface points of worm gear (Fig. 3). On Fig. 3 it could be seen the touched tooth surface points by the cutting edge of hob namely the tooth surface points of worm gear in the  $y_{2F} - z_{2F}$  plane.

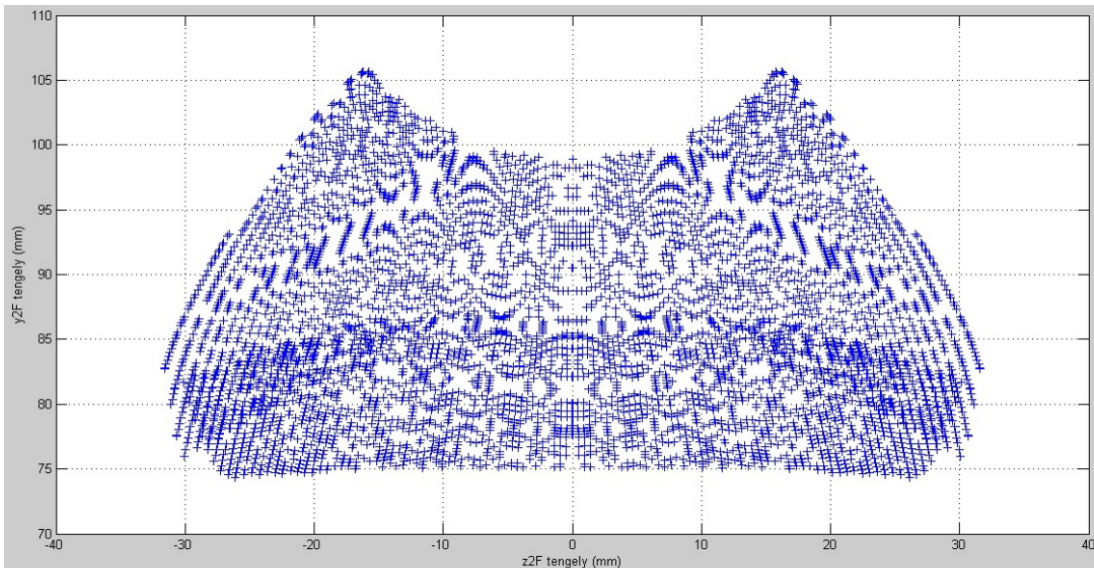
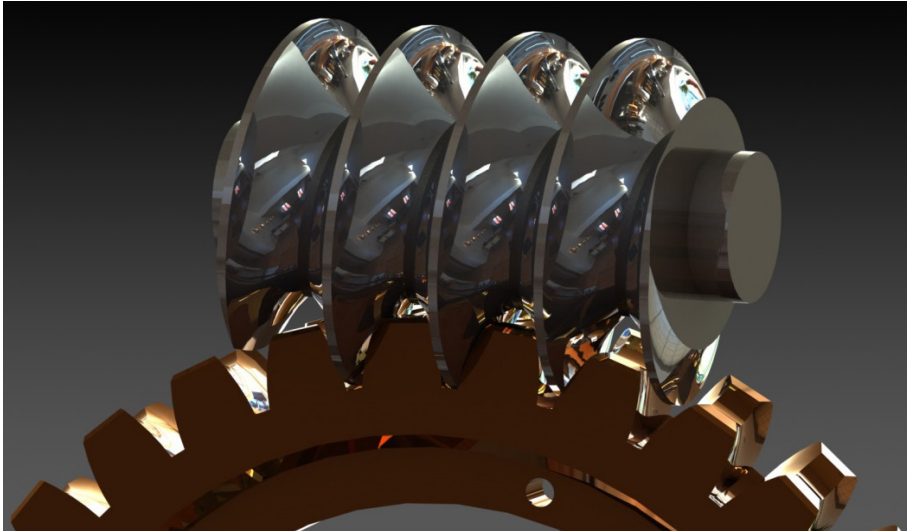

**Figure 3. Determination of tooth surface points of worm gear**



#### 4. COMPUTER AIDED MODELLING

The generated TXT file by computer program is imported to Solid Works designer software. On the profile points interpolating B spline was drawn, then tooth profile, along the circumference of the worm gear, was determined according to number of the gear cogs [1]. Limiting of the dentation territory has been occurred based on geometric data and technical drawing of the worm gear drive [2, 3].



*a) Connection cylindrical worm – worm gear model*

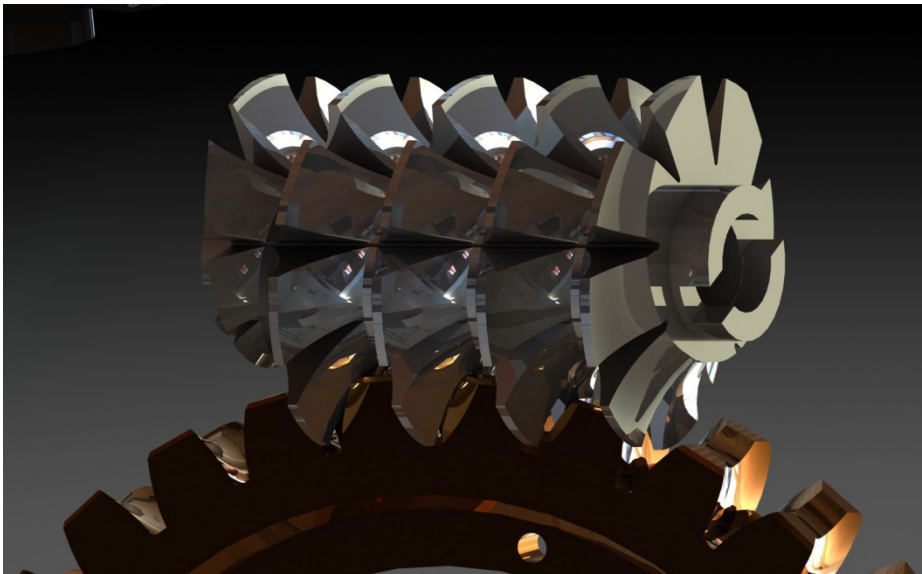

*b) Connection cylindrical hob – worm gear model*

*Figure 4. CAD models of cylindrical worm, hob and worm gear*



Using the stated mathematical method for determination of the tooth surface points of worm gear, the worked out computer program and the Solid Works designer software the CAD models of cylindrical worm gear drive (worm, worm gear and hob) could be produced (Fig. 4).

## 5. CONCLUSION

The tooth surface of worm gear is determined by the worm dentation based on mutual wrapping. That is why in case of toothing the worm gear has to be produced by hob which has similar geometry to worm.

Knowing the cutting edges of the hob we have determined the wrapped surface by the hob by numerical way namely the tooth surface of the worm gear.

We have connected interpolating B – spline surface for the tooth surface points of worm gear and after produced the CAD models of cylindrical worm, worm gear and hob.

The received CAD model is suitable for other Finite Element Analysis and connection analysis.

## REFERENCES

- [1] Bodzás, S.: Kúpos csiga-, tányérkerék- és szerszám felületek kapcsolódásának elemzése, Ph.D. dissertation, University of Miskolc, 2014., p. 154.
- [2] Dudás, I.: Ívelt profilú csigahajtás egyszerűsített gyártása és minősítése, University doctoral dissertation, Miskolc, 1973.
- [3] Dudás, I.: The Theory & Practice of Worm Gear Drives. Kogan Page US, Sterling, USA, 2004.
- [4] Dudás, I.: Ívelt profilú csigahajtások szerszámozásának és gyártásának fejlesztése, Candidate dissertation, Miskolc, 1980. p.153+30 attachment
- [5] Dudás, I.: Csavarfelületek gyártásának elmélete. Academic doctoral dissertation, Miskolc, 1991.
- [6] Krivenko, I. SZ.: Novüie tipü cšervjacsnüh peredacs na szudah, Izd. Szudoszrovenie, Leningrád, 1967.
- [7] Litvin, F. L., Fuentes, A.: Gear Geometry and Applied Theory, Cambridge University Press, 2004.
- [8] Niemann, G.: Maschienenenelemente. Band.2., Sprienger-Verlag, Berlin, Heidelberg, New York, Tokyo, 1965.